

THIS DRAWING IS UNPUBLISHED. RELEASED FOR PUBLICATION
 © COPYRIGHT BY TYCO ELECTRONICS CORPORATION. ALL RIGHTS RESERVED.

LOC	DIST	REVISIONS			
P	LTR	DESCRIPTION	DATE	DWN	APVD
FT	0	T	REVISED PER 0G3B-0668-02	12/18/02	SS SH

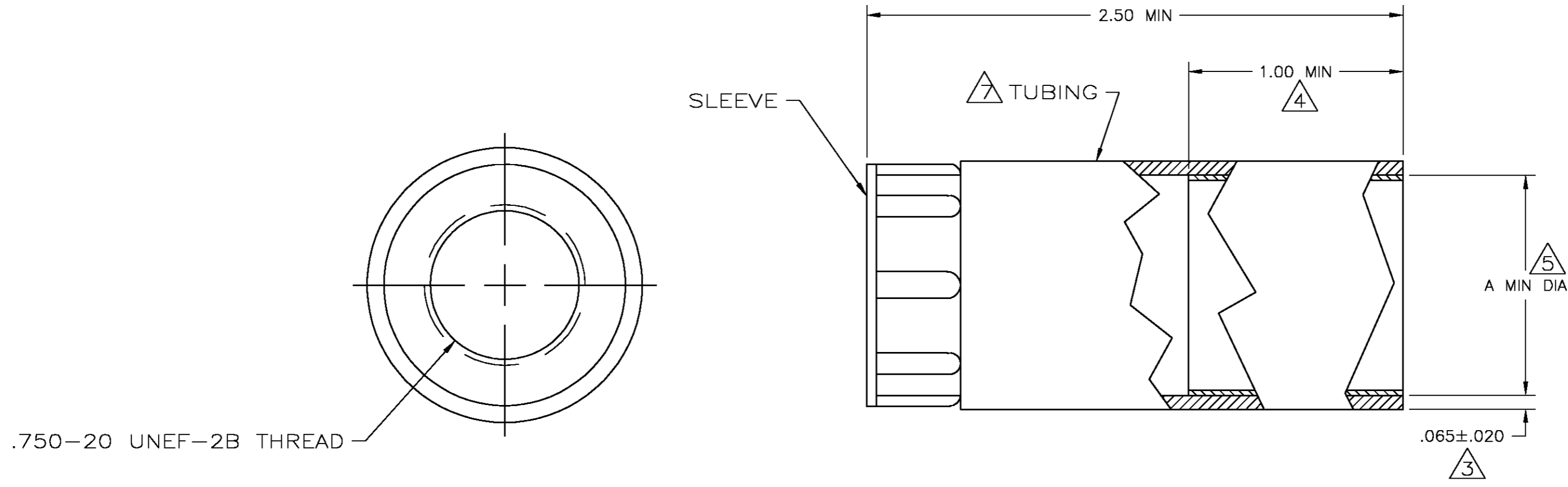

NOTES:

- 1 POLYOLEFIN, BLACK.
- 2 NYLON, BLACK.
- 3 NOMINAL WALL THICKNESS, EXPANDED.
- 4 LENGTH OF SEALANT.
- 5 EXPANDED INSIDE DIAMETER.
- 6. ASSEMBLY WILL PASS 0.0703 KG PER SQ CENTIMETER [ONE POUND PER SQ IN.] WATER PRESSURE TEST.
- 7 121°C [250°F] SHRINK TEMPERATURE.
- 8. -55°C TO 110°C [-67°F TO 230°F] OPERATING TEMPERATURE.

.980	.250-.375	.195	54123-2
.775	.375-.725	.300	54123-1
A 5	CABLE DIA RANGE	MAXIMUM RECOVERED INSIDE DIAMETER	PART NUMBER

THIS DRAWING IS A CONTROLLED DOCUMENT.		DWN	02 SEP 99	Tyco Electronics Corporation Harrisburg, PA 17105	
DIMENSIONS: INCHES		CHK	-	NAME	
TOLERANCES UNLESS OTHERWISE SPECIFIED:		APVD	-	PRODUCT SPEC	
0 PLC ± -		APPLICATION SPEC		STRAIN RELIEF ASSY, SHELL, SIZE 13, CPC	
1 PLC ± -		WEIGHT		SIZE	RESTRICTED TO
2 PLC ± -		A2		CAGE CODE	00779
3 PLC ± -		CUSTOMER DRAWING		DRAWING NO	C=54123
4 PLC ± -		SCALE 2:1		SHEET	1 OF 1
ANGLES ± -		REV		T	
FINISH -					